

Modular Drills – KentTIP Application Guidelines

SOLID CARBIDE DRILLS

MODULAR DRILLS

COMBINATION TOOLS

HSS AND CARBIDE TAPS

Mounting the KentTIP Inserts

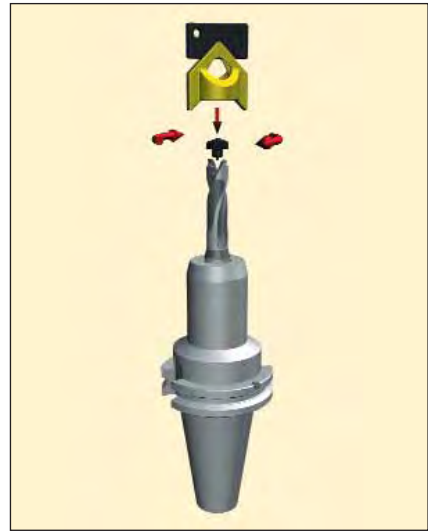
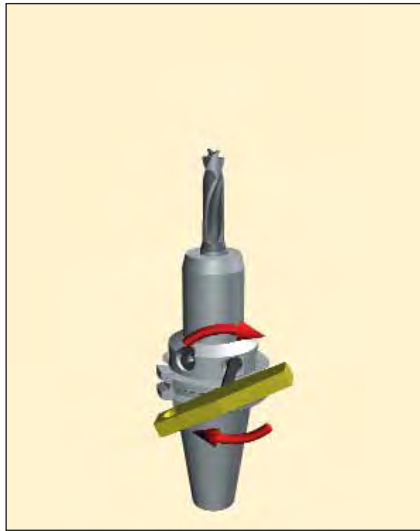

INDEXABLE DRILLS

COUNTERBORING TOOLS

PRECISION HOLE FINISHING

INSERTS

Cooling the KentTIP Drill

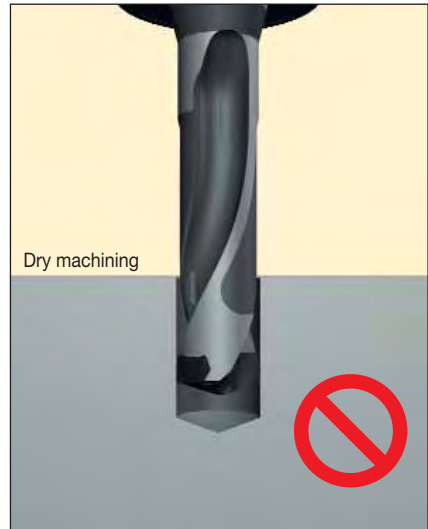
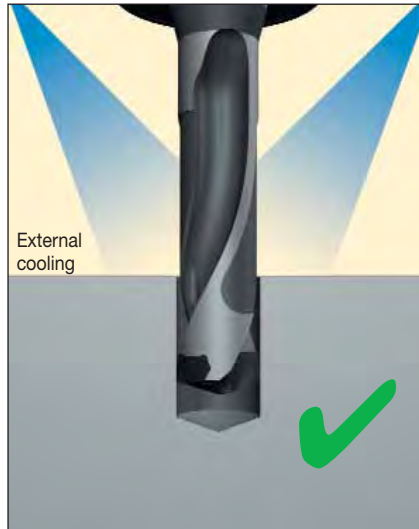
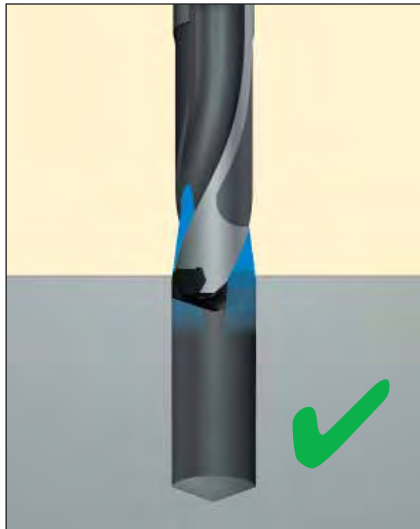

only when using the 3 x D tool bodies

Note

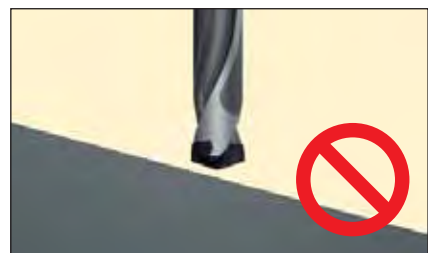
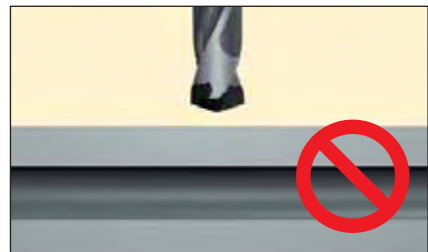
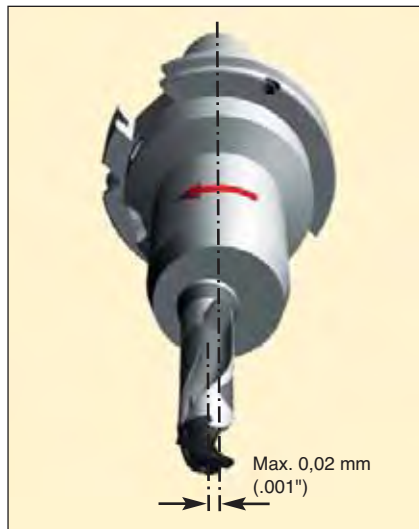
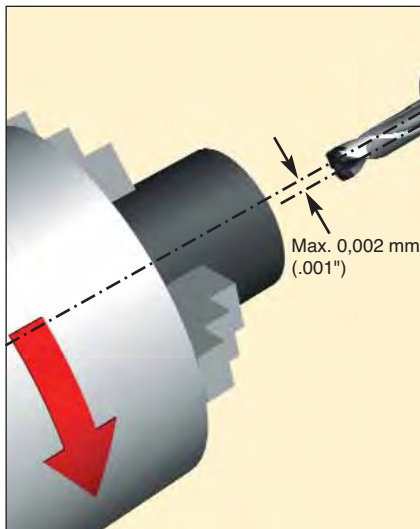

TECHNICAL DATA

INDEX

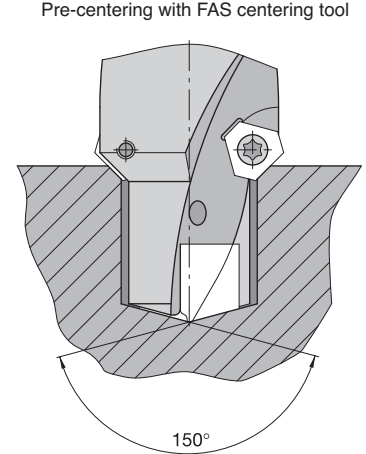
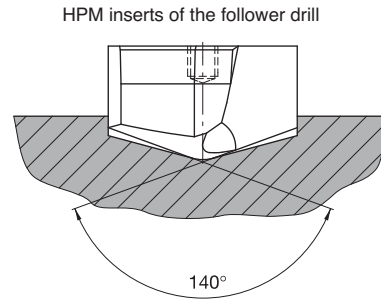
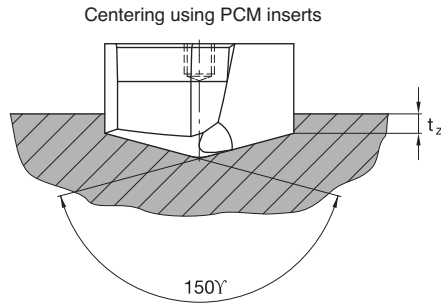

Why is pre-centering necessary?

- Generally speaking, for drilling depths 5 times the nominal diameter and above (5 x d).
- In unstable conditions (workpiece and tool clamping).

Why pre-center using PCM inserts?

- Soft cut entry of follower drill due to 150° point angle of the PCM insert.
- No extension of the follower drill in the entry area.
- No breaks at the cutting edges.

What happens if...

... a center cannot be used for technical reasons?

Spot drill with “normal” insert and reduced cutting data (approximately ½ vc and approximately ½ vf) then continue drilling with regular cutting data without lifting off/stopping.

...there is no suitable PCM cutting insert in the standard range (ø)?

- Manufacture to order using PCM geometry and k7 tolerance
or
- Center using the same cutter insert as for the follower drill but without the cutting edges penetrating the workpiece (spot drill ø approximately 90% of drill ø d1).

...only one tool body is required?

Enter the workpiece with 50% feed until the cutting edges and the heels have penetrated the hole, then continue drilling without lifting off/stopping using regular cutting data.

Other problems...

Short hole drilling with pre-centering support tool?

Up to 1 x nominal diameter (1 x d) possible.

Modular Drills – Technical Data – Workpiece Rigidity

SOLID CARBIDE DRILLS

MODULAR DRILLS

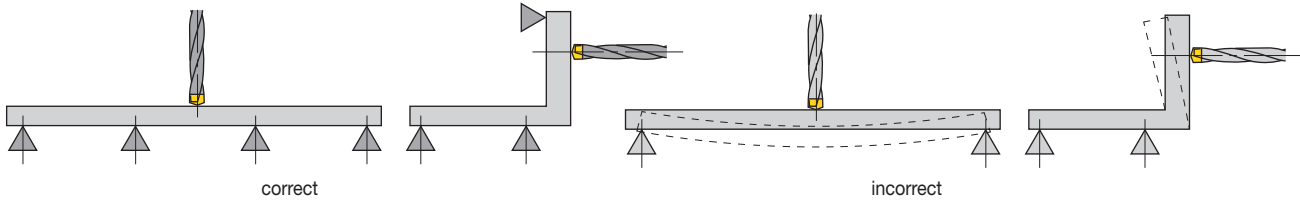

Because KSEM drills deliver much higher penetration rates, it is important that the workpiece receive adequate support.

COMBINATION TOOLS

HSS AND CARBIDE TAPS

INDEXABLE DRILLS

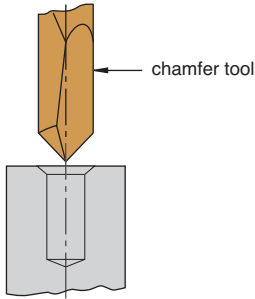

When drilling and chamfering, drill into the solid first, then chamfer.



When drilling on inclined surfaces $\leq 5^\circ$, reduce feed by 50% until entire drill margin is in the cut, then resume full feed.

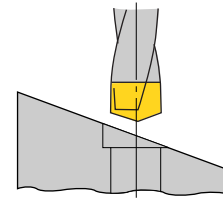

Before drilling on curved or inclined surfaces $>5^\circ$, pre-machining ($\phi D + .004$) is required.

COUNTERBORING TOOLS

PRECISION HOLE FINISHING

INSERTS

TECHNICAL DATA

INDEX



When drilling stacked plates, care must be taken. The KSEM drill will push a slug.

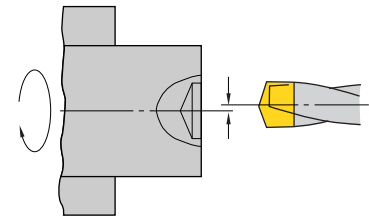
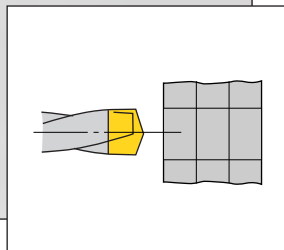

When drilling on turning machines, positioning the drill on center is a must.

CAUTION

During through-hole operations, a slug or disc is produced as the tool breaks through the workpiece. When the drill is stationary and the workpiece is rotating, this slug may be hurled from the chuck by centrifugal force. Provide adequate shielding to protect all bystanders.

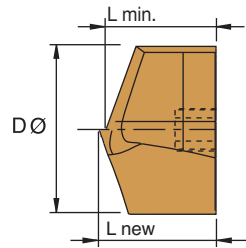
Minimum insert length after reconditioning

inch				mm			
D diameter range	L min.	L new	seat size	diameter range	L min.	L new	
.492 - .531	.335	.378	C	12,50 - 13,50	8,5	9,6	
.532 - .570	.350	.398	B	13,51 - 14,50	8,9	10,1	
.571 - .624	.370	.417	A	14,51 - 15,87	9,4	10,6	
.625 - .709	.406	.457	1	15,88 - 18,00	10,3	11,6	
.710 - .786	.441	.496	2	18,01 - 19,99	11,2	12,6	
.787 - .866	.476	.535	3	20,00 - 22,00	12,1	13,6	
.867 - .945	.512	.575	4	22,01 - 24,00	13,0	14,6	
.946 - 1.024	.547	.614	5	24,01 - 26,00	13,9	15,6	
1.025 - 1.102	.583	.654	6	26,01 - 28,00	14,8	16,6	
1.103 - 1.181	.618	.693	7	28,01 - 30,00	15,7	17,6	
1.182 - 1.260	.654	.732	8	30,01 - 32,00	16,6	18,6	
1.261 - 1.417	.724	.811	9	32,01 - 36,00	18,4	20,6	
1.418 - 1.575	.795	.890	10	36,01 - 40,00	20,2	22,6	

Wear or failure mechanisms to avoid when applying KSEM Insert Blades

The blades (shown below) typically cannot be reconditioned as the amount removed during the grinding process would place the cutting edge below the steel pocket of the KSEM body.

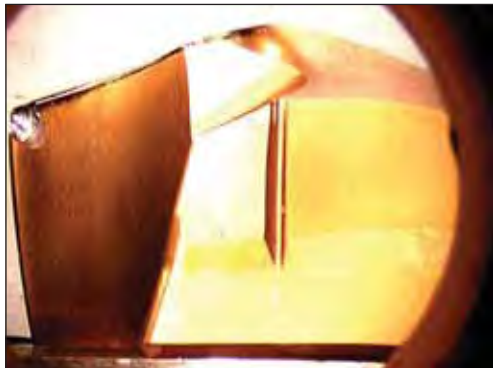

large fracture on corners



excessive margin wear

Modular Drills – Cutting Forces – KenTIP

Performance Diagrams Note:

The diagrams are used to determine the feed force, drive power, and torque. They are based on cutting force measurements in steel with a tensile strength of: $R_m = 800 \text{ N/mm}^2$. The base cutting speed used is: $v_c = 80 \text{ m/min}$ (260 sfm).

Drive Power

P_s [kW] Drive Power

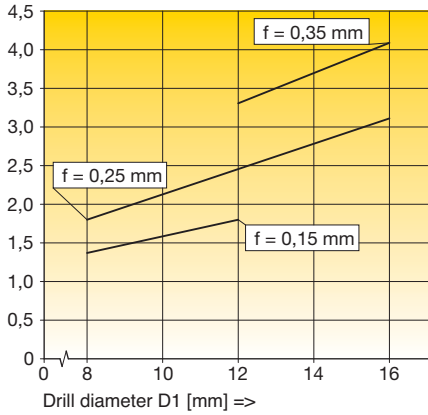

Feed Force

F_f [kN] Drive Power

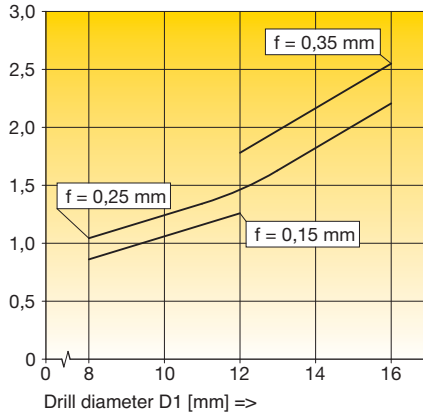

Torque

M_d [Nm] Drive Power

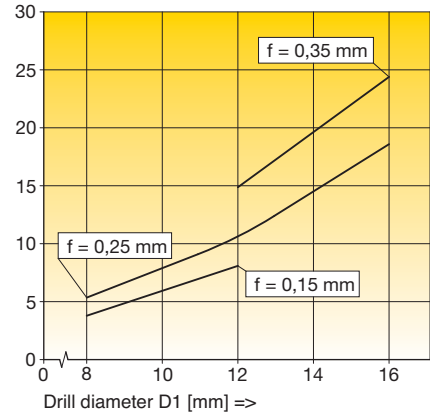

SOLID CARBIDE DRILLS

MODULAR DRILLS

COMBINATION TOOLS

HSS AND CARBIDE TAPS

INDEXABLE DRILLS

COUNTERBORING TOOLS

PRECISION HOLE FINISHING

INSERTS

TECHNICAL DATA

INDEX

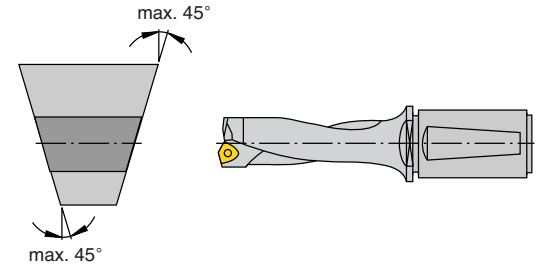
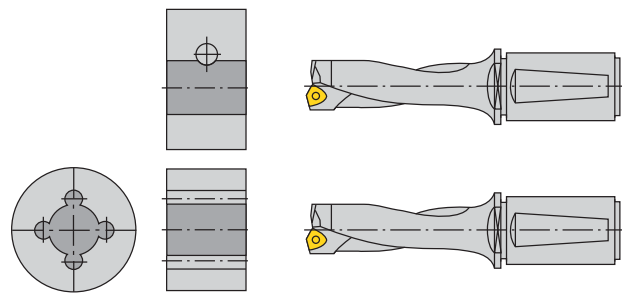
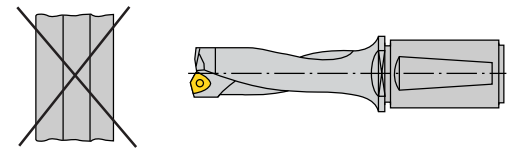
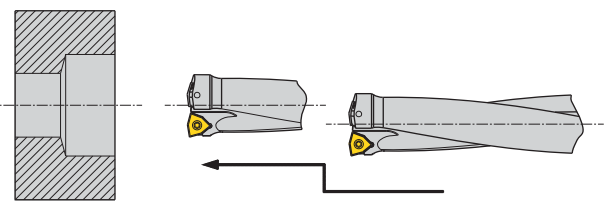
operation	description
<p>spot drilling and drilling through on inclined surfaces</p> 	<p>Up to a 30° inclination angle is possible without reducing the cutting parameters. For angles between 30-40°, reduce feed force at incline surface by 50% (compared to values shown above in starting conditions).</p>
<p>interrupted cuts</p> 	<p>For problem-free drilling in interrupted cuts (cross drilling, etc.), reduce the cutting force and feed by 30% to maintain maximum stability of the machine and clamping mechanisms.</p>
<p>drilling of stacked plates</p> 	<p>This is not possible with the standard DRILL-FIX series drills. A final disc will form when the drill breaks through. Special DRILL-FIX drills may be quoted upon request for stacked plate drilling.</p>
	<p>When DRILL-FIX tools are used as a boring tool, offset the drill in the direction of the outer insert. Watch the outer insert for wear because it is cutting more metal than the inner insert and may require more frequent indexing.</p>

WARNING

During through-hole operations, a slug or disc is produced as the tool breaks through the workpiece. When the drill is stationary and the workpiece is rotating, this slug may be hurled from the chuck by centrifugal force. Provide adequate shielding to protect all bystanders.

SOLID CARBIDE DRILLS

MODULAR DRILLS

COMBINATION TOOLS

HSS AND CARBIDE TAPS

INDEXABLE DRILLS

COUNTERBORING TOOLS

PRECISION HOLE FINISHING

INSERTS

TECHNICAL DATA

INDEX